

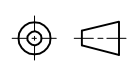

CABLE LENGTH	TOLERANCE*
ALL LENGTHS	+ 4% (OR 50mm) OF LENGTH - 0% (OR 0mm) OF LENGTH WHICHEVER IS GREATER
STRIP LENGTH	TOLERANCE*
0-7mm	±0.5mm
8-29mm	±1.0mm
30-49mm	±2.0mm
50-69mm	±3.0mm
70-100mm	±4.0mm
OVER 100mm	±5.0mm
<b>* UNLESS OTHERWISE SPECIFIED</b>	

NOTES:

1. "\*" INDICATES CABLE LENGTH IN METERS. CONTACT TURCK TO ORDER SPECIFIC LENGTHS.

**SOURCE DRAWING - FOR REFERENCE ONLY**

RELATED DOCUMENTS 1. 2. 3. 4.	3RD ANGLE PROJECTION 	THIS DRAWING IS CONFIDENTIAL AND THE PROPERTY OF TURCK INC. USE OF THIS DOCUMENT WITHOUT WRITTEN PERMISSION IS PROHIBITED.		3000 CAMPUS DRIVE MINNEAPOLIS, MN 55441 1-800-544-7769 (763) 553-7300 (763) 553-0708 fax www.turck.us
MATERIAL  SEE SPECIFICATIONS	ALL DIMENSIONS DISPLAYED ON THIS DRAWING ARE FOR REFERENCE ONLY	DRFT RDS DATE 08/12/05	DESCRIPTION  RK 4T-*--PSG 3	
FINISH  SEE SPECIFICATIONS		APVD SCALE 1=1.0		
		UNIT OF MEASUREMENT <b>MILLIMETER [ INCH ]</b>		IDENTIFICATION NO.
		CONTACT TURCK FOR MORE INFORMATION		REV <b>C</b>
C DRAWING PROCESSED AS PART OF ECO 33971		CBM 04/06/11 33971		DO NOT SCALE THIS DRAWING
REV DESCRIPTION		BY DATE ECO NO.		FILE: 777007727
				SHEET 1 OF 1